



17800 N 85TH STREET  
SCOTTSDALE, ARIZONA 85255

---

AXON.COM

To Whom It May Concern,

This document provides an overview of Axon's five-year useful life recommendation for its TASER® conducted electrical weapons (CEWs).

Despite their rather simple external appearance, TASER CEWs are complex electrical devices. A typical TASER X2™ / X26™ CEW is composed of hundreds of individual electronic components and several printed circuit boards and their associated interconnections. The internal components of a TASER CEW represent two unique electronic circuit types. The first and most obvious is the High Voltage Section. Its job is to convert a relatively low battery power into a complex precision-shaped high voltage, low current output. The high voltage section by nature is an electrical circuit that relies on electromagnetic components, transformers, high voltage coils, electrolytic, and polymer capacitors. The controller section, by contrast, is an infinitely more complex sub-circuit system consisting of multiple microprocessors responsible for keeping track of time, displaying information to the user, maintaining the accountability systems of the device, and controlling the output of the high voltage system.

It is for these reasons that Axon strongly discourages the use of TASER CEWs after five years of use. Further, while Axon will indefinitely defend TASER technology, the defense of outdated devices poses substantial challenges and the risk increases with time. It is for these same reasons that Axon will not service or repair weapons older than five years and does not provide its product liability insurance certificate to agencies fielding weapons of this age.

As with other sophisticated electrical devices, TASER CEWs wear out over time. Indeed, the following chart shows the recommended useful life of several common consumer electronic products (Figure 1):

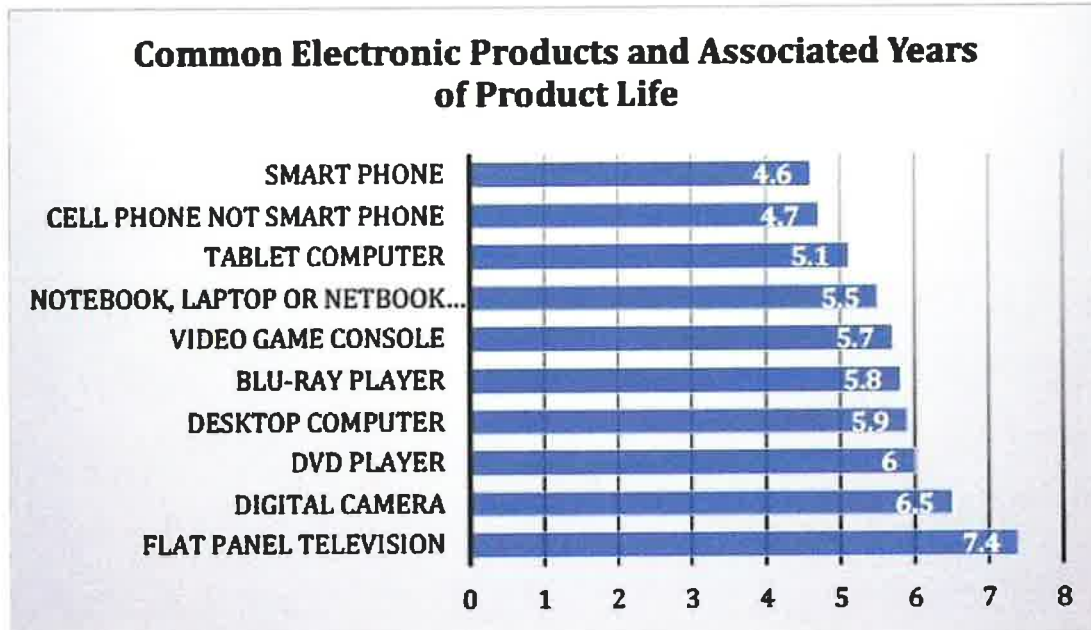

Figure 1: Typical Life of Common Electronic Products

A fundamental difference between TASER CEWs and the consumer products listed above is that TASER CEWs are regularly exposed to far harsher conditions than most consumer products, including inclement weather (which can cause thermal shock and electrical overstress), as well as the constant physical stress associated with law enforcement work.

Specifically, there are several electronic components used in the assembly of a TASER energy weapon that are particularly affected by their serviceable life. While most of these components are rated to live much longer than our specified service life, they are directly and adversely affected by the use and usage environments that energy weapons are exposed to. The list below details these conditions along with a technical explanation of how they adversely impact the useful life:

- Thermal Shock: Our energy weapons are exposed to extreme temperature variation. On a daily basis, an officer may be getting in and out of a heated or air conditioned vehicle and operating in the exact opposite environment. These regular, sudden changes of temperature stress the mechanical and electronic components inside the weapon, including the capacitors, microprocessors, battery contacts and high voltage coils.
- Electromigration: The movement of ions in an electrical circuit physically builds up between opposing polarities at the microscopic level. This build



17800 N 85TH STREET  
SCOTTSDALE, ARIZONA 85255

AXON.COM

up may impact the operation of integrated circuits and memory chips, and eventually impact connections on the printed circuit board itself.

- Electrical Overstress: There are some components in a TASER energy weapon - such as the high voltage transformers and capacitors - that operate in or at the upper end of its normal operating range, which can shorten the service life of those components.
- Humidity: Humidity (water in the atmosphere) can be absorbed by electronic components, such as the microprocessors and battery contacts, and have an adverse effect on their performance.
- Galvanic Corrosion: Electronic components - particularly battery contacts, electrical connectors or other metallic terminations - can be affected by water and particulates in the air. This causes a chemical reaction that can build up over time and lead to component failure.

Additionally, the implementation of pooled/shared models accelerates usage, while simultaneously decreasing our recommended useful life and increasing the risk to both the police officer and relevant subject(s). Our recommended useful life of 5 years is based off of a single user model, so the pooled/shared model considerably shortens the expected and recommended useful life of the CEW. The pooled/shared model expedites the 'wear & tear' of the device both as a result of increased usage in the field, and due to the fact that function checks/tests are mandated before the start of a new shift for each law enforcement officer. Pooled devices being used after the recommended useful life are especially at risk for malfunctions due high amounts of use of internal components, and extended exposure to various elements.

A picture of the internal components of the TASER X2 can be seen below in Figure 2, which depicts several of the components that experience wear over time.

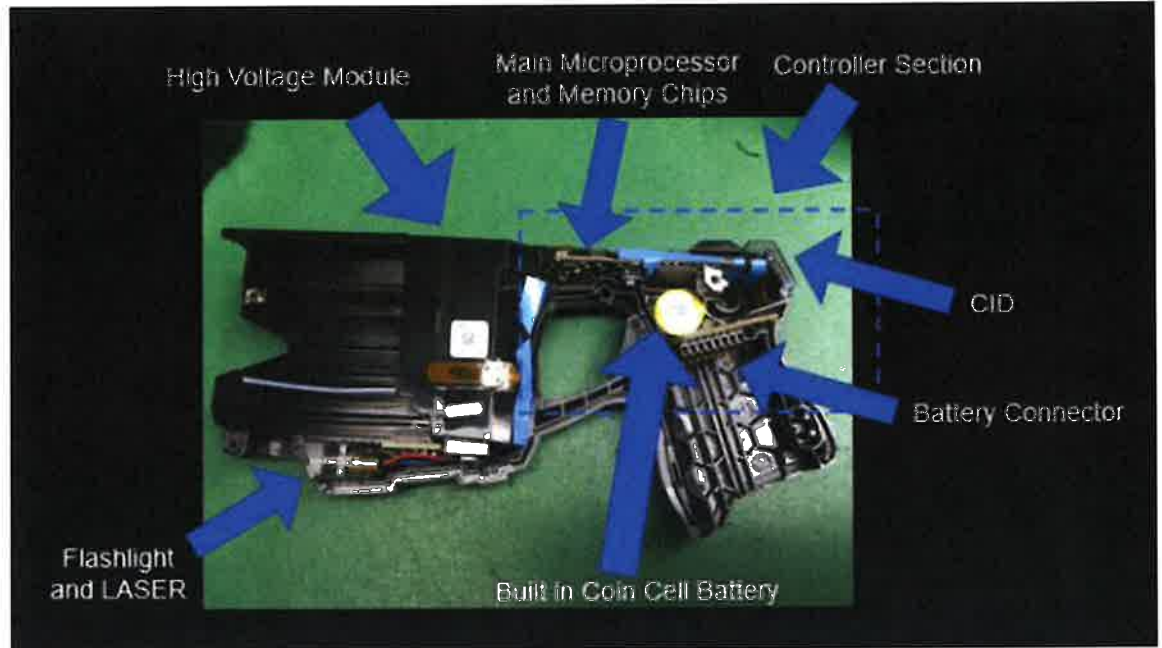

Figure 2: Cutaway View of TASER X2 with Labeled Internal Components

A picture of the internal components of the TASER X26P can be seen below in Figure 3, which depicts several of the components that experience wear over time.

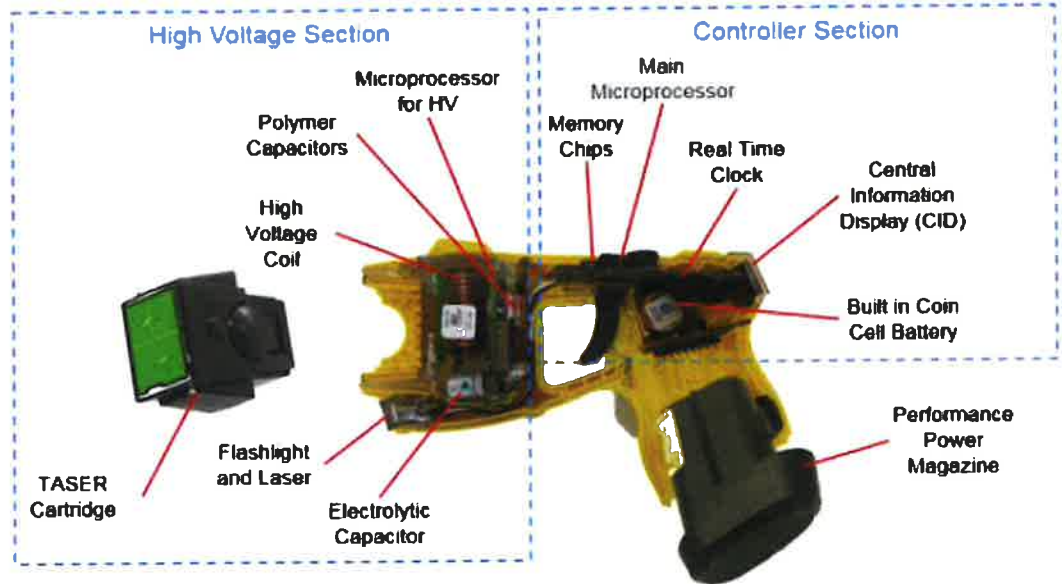

Figure 3: Cutaway View of TASER X26P with Labeled Internal Components

TASER Cartridges also become less reliable after 5 years from the manufacturing date. For this reason, an expiration date is engraved on all TASER Cartridges, and Axon recommends they not be used in the field after the expiration date. If the agency desires, expired cartridges may be used *for training purposes only*, as there is no additional safety risk to using cartridges after the expiration date, but they may not produce the same intended outcome as expected in the field.

The two key cartridge components that carry increased risk after 5 years are the nitrogen (gas) capsule and the primer. Each of these components are integral to the cartridge properly deploying with sufficient energy to fly downrange and penetrate clothing. In order to initiate the firing sequence, the primer is ignited with electrical current. Over time, environmental conditions such as humidity may change the chemical composition of the primer, which decreases the energetic output. The nitrogen (gas) capsule is LASER welded to seal over 1800 pounds per square inch of pressurized gas. Over time, microscopic leaks can allow a small amount of gas to escape, which would cause the probes to deploy with less velocity, resulting in a shorter range distance.

The internal components of the TASER Standard Cartridge can be seen

below in Figure 4.

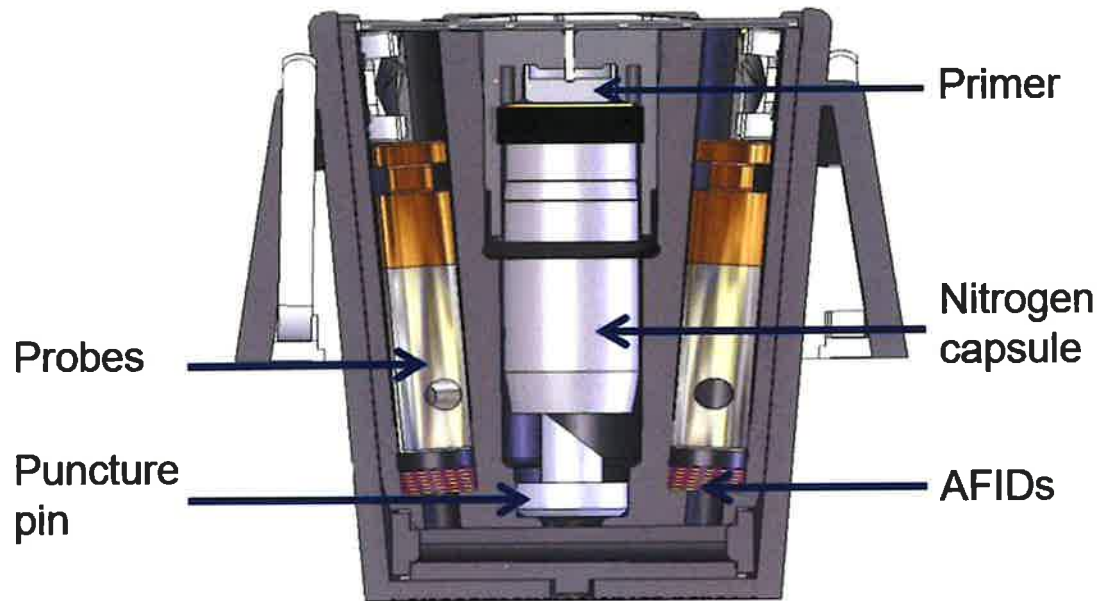

Figure 4: Cutaway View of Standard Cartridge with Labeled Internal Components

Due to the complexities of TASER devices and cartridges noted above, Axon recommends using TASER devices only within the five-year useful life.

Sincerely,

*Willie Pirc*

Director of TASER Products